

## MR20 PRESS+ WELDER FOR PLASTIC ASSEMBLY

- .Plastics industry
- .Automotive industry
- .Electric products
- .Packaging and Clothing
- .Medikal products
- .Stationery and Toys
- .Food industry
- .Textile industry



### FEATURES

- .Time and Energy mode
- .Amplitude control
- .Automatic frequency tuning
- .Weld time
- .Hold time
- .Delay time
- .Afterburst time
- .Touch screen/Rotary encoder
- .Ultrasonic load meter scale
- .Over load, No load, Short circuit, Overtemperature

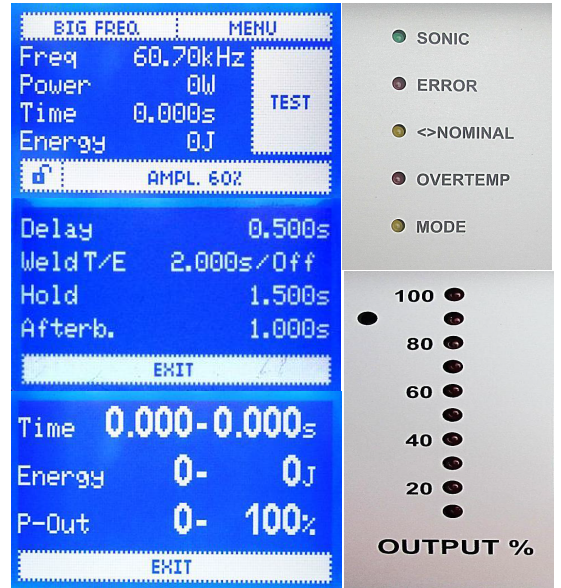

Mirtest Ultrasonic Ltd.Şti.

Yeni Mh.Abdulhalik Renda Cd.Mukaddime Sk.No:11Pendik İstanbul TURKEY

Phone:+90 (216) 375 87 78- +90 (216) 446 57 28 Fax:+90 (216) 375 87 48

E-Mail:info@mirtestultrasonic.com Web:www.mirtestultrasonic.com

MR20 PRESS +  
WELDER FOR PLASTIC ASSEMBLY

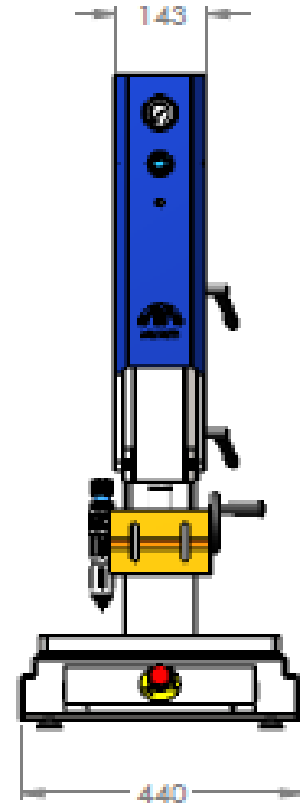
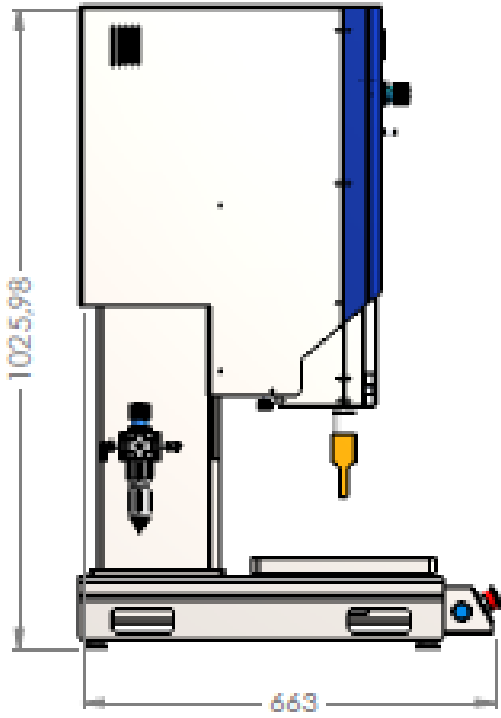

### TECHNICAL FEATURES

- .Operating frequencies 20 KHz
- .Output power 500 to 4000 Watts
- .Weight around 100 Kg
- .Table dimensions 300x400
- .Head cylinder stroke 100 mm
- .Diameter of cylinder Ø80
- .Adjustment of head position 500 mm
- .Air feed 6 Bars
- .Head speed adjustable with manuel flow control valve
- .Head pressure adjustable with manual pressure regulator